

# Anti-Two Block

## Switch 0011



A2B switch iSENS HES consists of a switching unit and an optional divisible operating weight. When installed correctly the A2B switch serves as positive break limit switch for use on winches, lifting equipment and cranes.

The A2B switch is accepted as final limit switch by Institute for Occupational Safety and Health (IFA) of the German Social Accident Insurance (DGUV) with test number 1104028.

For monitoring the electrical connection cable 1 or 2 range resistors are included, depending on type. The electrical functional part is completely sealed and thus provides excellent protection against harmful environmental influences.

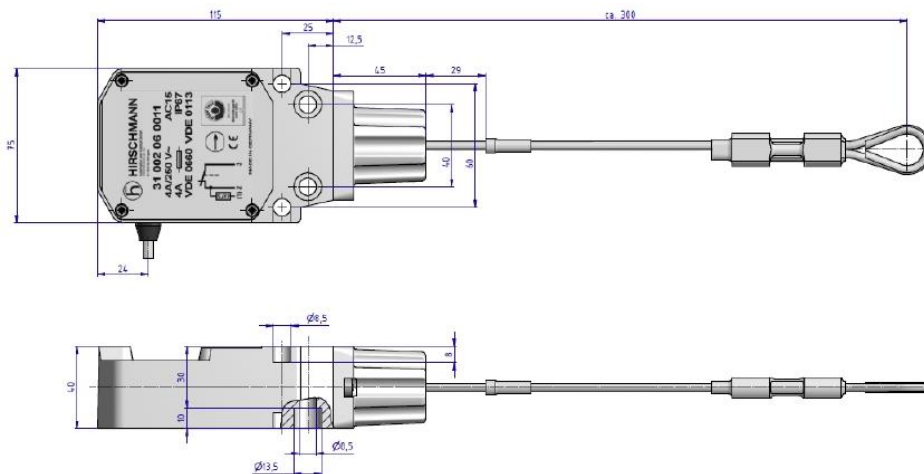

Actuation diagram

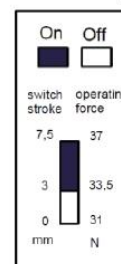

Circuit diagram

